



parweld

XTM 211Di

OPERATOR MANUAL

ISSUE 1

Welcome

Thank you for choosing Parweld. This Owner's Manual is designed to help you get the most out of your Parweld products. Please take time to read the Safety Precautions. They will help you protect yourself against potential hazards in the workplace. With proper maintenance this equipment should provide years of reliable service. All our systems conform to ISO9001: 2015 and are independently audited by NQA.

The entire product range carries the CE mark, and is constructed in accordance with European directives and the product specific standards where they apply.

Further Information

Parweld is the UK's leading supplier of MIG, TIG and Plasma torches and consumables.

For more information about Parweld's complete range visit: www.parweld.com



Contents

	Page
1.0 Safety Precautions	4-5
2.0 Product Description	5
3.0 Technical Specifications	6
4.0 Installation	6
4.1 Location	6
4.2 Input and Grounding Connection	6
5.0 Description of Controls and Torch Connections	7
6.0 Operation	8-10
6.1 Use of Controls	8
6.2 Language of Operation	8
6.3 Process Selection	8
6.4 MIG Welding Preparing the Machine	9-10
7.0 Setting the Machine for Welding	10-19
7.1 MIG Torch Selection	10
7.2 MIG SYN - Synergic MIG Welding	10-11
7.3 MIG MAN - Manual MIG Welding	11
7.4 Remote Control MIG Torch	11
7.5 MIG Welding Procedure	12
7.6 MMA Welding	12
7.7 TIG Welding	12
7.7.1 TIG Torch Selection	12
7.7.2 TIG Torch Installation	13
7.7.3 TIG Welding Setup	13-15
7.7.4 TIG Welding Guide	15
7.7.5 DC TIG Welding (No Pulse)	15-16
7.7.6 AC TIG Welding (No Pulse)	16-17
7.7.7 TIG Welding (With Pulse)	17-18
7.8 Saving to Memory	18
7.9 Process Switch	18-19
8.0 Fault Finding	19-22
8.1 MIG Welding Problems	19-20
8.2 MMA Welding Problems	21
8.3 TIG Welding Problems	22
9.0 Control Torch Schematic	23
10.0 Accessories	24
10.1 Feed Rolls	24
10.2 Torch Spares	24
10.3 Gas Equipment	24
11.0 EC Declaration of Conformity	25-26
11.1 RoHS Compliance Declaration	25
11.2 WEEE Statement	26
11.3 Statement of Warranty	26

1.0 Safety Precautions

ELECTRIC SHOCK can kill.

Touching live electrical parts can cause fatal shocks or severe burns. The electrode and work circuit is electrically live whenever the output is on. The input power circuit and machine internal circuits are also live when power is on. In semi automatic or automatic wire welding, the wire, wire reel, drive roll housing, and all metal parts touching the welding wire are electrically live. Incorrectly installed or improperly grounded equipment is a hazard.

Do not touch live electrical parts.

Wear dry, sound insulating gloves and body protection.

Insulate yourself from work and ground using dry insulating mats or covers big enough to prevent any physical contact with the work ground.

Additional safety precautions are required when any of the following electrically hazardous conditions are present: in damp locations or while wearing wet clothing; on metal structures such as floors, gratings, or scaffolds; when in cramped positions such as sitting, kneeling, or lying; or when there is a high risk of unavoidable or accidental contact with the work piece or ground. For these conditions, use the following equipment in order presented: 1) a semi automatic DC constant voltage (wire) welder, 2) a DC manual (stick) welder, And, do not work alone!

Disconnect input power before installing or servicing this equipment. Lockout/tagout input power according to Safety Standards.

Properly install and ground this equipment according to national and local standards.

Always verify the supply ground - check and ensure that input power cable ground wire is properly connected to ground terminal in the receptacle outlet.

When making input connections, attach proper grounding conductor first - double-check connections.

Frequently inspect input power cable for damage or bare wiring - replace cable immediately if damaged - bare wiring can kill.

Turn off all equipment when not in use.

Do not use worn, damaged, under sized, or poorly spliced cables.

Do not drape cables over your body.

If earth grounding of the work piece is required, ground it directly with a separate cable.

Do not touch electrode if you are in contact with the work, ground, or another electrode from a different machine.

Use only well-maintained equipment. Repair or replace damaged parts at once. Maintain unit according to manual.

Wear a safety harness if working above floor level.

Keep all panels and covers securely in place.

Clamp work cable with good metal-to-metal contact to work piece or worktable as near the weld as practical.

Insulate work clamp when not connected to work piece to prevent contact with any metal object.

Welding produces fumes and gases. Breathing these fumes and gases can be hazardous to your health.

FUMES AND GASES can be hazardous.

Do not breathe the fumes.

Ensure local extraction is effective or use personal filtration system. Welding fume can be carcinogenic.

Read and understand the Material Safety Data Sheets (MSDS's) and the manufacturer's instructions for metals, consumable, coatings, cleaners, and de-greasers.

Work in a confined space only while wearing an air-supplied respirator. Always have a trained watch person nearby. Welding fumes and gases can displace air and lower the oxygen level causing injury or death. Be sure the breathing air is safe.

Do not weld in locations near de-greasing, cleaning, or spraying operations. The heat and rays of the arc can react with vapours to form highly toxic and irritating gases.

Do not weld on coated metals, such as galvanized, lead, or cadmium plated steel, unless the coating is removed from the weld area, the area is well ventilated, and while wearing an air-supplied respirator. The coatings and any metals containing these elements can give off toxic fumes if welded.

ARC RAYS can burn eyes and skin.

Arc rays from the welding process produce intense, visible and invisible (ultraviolet and infrared) rays that can burn eyes and skin. Sparks fly off from the weld.

Wear an approved welding helmet fitted with a proper shade of filter lenses to protect your face and eyes when welding or watching

Wear approved safety glasses with side shields under your helmet.

Use protective screens or barriers to protect others from flash, glare and sparks; warn others not to watch the arc.

Wear protective clothing made from durable, flame resistant material (leather, heavy cotton, or wool) and foot protection. Welding on closed containers, such as tanks, drums, or pipes, can cause them to blow up. Sparks can fly off from the welding arc. The flying sparks, hot work piece, and hot equipment can cause fires and burns. Accidental contact of electrode to metal objects can cause sparks, explosion, overheating, or fire. Check and be sure the area is safe before doing any welding.

WELDING can cause fire or explosion.

Remove all flammables within 10m of the welding arc. If this is not possible, tightly cover them with approved covers.

Do not weld where flying sparks can strike flammable material.

Protect yourself and others from flying sparks and hot metal.

Be alert that welding sparks and hot materials from welding can easily go through small cracks and openings to adjacent areas.

Watch for fire, and keep a fire extinguisher nearby. Be aware that welding on a ceiling, floor, bulkhead, or partition can cause fire on the hidden side.

Do not weld on closed containers such as tanks, drums, or pipes, unless they are properly prepared according to local regulations

Connect work cable to the work as close to the welding area as practical to prevent welding current from travelling along, possibly unknown paths and causing electric shock, sparks, and fire hazards.

Cut off welding wire at contact tip when not in use.

Wear oil-free protective garments such as leather gloves, heavy shirt, cuffless trousers, high shoes, and a cap. Remove any combustibles, such as a butane lighter or matches, from your person before doing any welding.

FLYING METAL can injure eyes.

Welding, chipping, wire brushing, and grinding cause sparks and flying metal. As welds cool they can throw off slag. Wear approved safety glasses with side shields even under your welding helmet.

BUILDUP OF GAS can injure or kill.

Shut off shielding gas supply when not in use. Always ventilate confined spaces or use approved air-supplied respirator.

HOT PARTS can cause severe burns.

Do not touch hot parts with bare handed.

Allow cooling period before working on gun or torch.

To handle hot parts, use proper tools and/or wear heavy, insulated welding gloves and clothing to prevent burns.

MAGNETIC FIELDS can affect pacemakers.

Pacemaker wearers keep away.

Wearers should consult their doctor before going near arc welding, gouging, or spot welding operations.

NOISE can damage hearing.

Noise from some processes or equipment can damage hearing.

Wear approved ear protection if noise level is high.

Shielding gas cylinders contain gas under high pressure.

CYLINDERS can explode if damaged.

Protect compressed gas cylinders from excessive heat, mechanical shocks, physical damage, slag, open flames, sparks, and arcs.

Install cylinders in an upright position by securing to a stationary support or cylinder rack to prevent falling or tipping. Keep cylinders away from any welding or other electrical circuits. Never drape a welding torch over a gas cylinder. Never allow a welding electrode to touch any cylinder. Never weld on a pressurized cylinder - explosion will result. Use only correct shielding gas cylinders, regulators, hoses, and fittings designed for the specific application; maintain them and associated parts in good condition.

Turn face away from valve outlet when opening cylinder valve.

Use the right equipment, correct procedures, and sufficient number of persons to lift and move cylinders.

Read and follow instructions on compressed gas cylinders, associated equipment, and Compressed Gas Association (CGA)

WARNING

When using an open arc process, it is necessary to use correct eye, head, and body protection.

2.0 Product Description

The XTM 211Di is a multi-mode welding machine using inverter technology. A micro controller allows the machine to be quickly and easily configured for MIG, TIG and MMA welding operations.

3.0 Technical Specifications

The XTM 211Di, is a compact type machine with integrated wire feed unit for use with single phase 110/230V supply with smart input switching.

Process	Feature	XTM 211Di	
		110V+/-10%	230V+/-10%
	Input Voltage	110V+/-10%	230V+/-10%
	Hz	50/60	
	Phases	1	
	KVA	3.7	
	Generator Size	7 KVA	
	No-load Voltage (V)	45V	
	Wire Drive	2 Roll	
	Fuse Rating (A)	32	16
	IP Rating	IP23S	
	Weight (Kg)	27.8	
MIG	DC Input Current (A)	39.1	30.0
	DC Input effective Current (A)	21.4	15.0
	DC Welding Current (A)	10~140	10~200
	Welding Voltage (V)	14.5~21	14.5~24
TIG	DC Input Current (A)	30.5	22.5
	DC Input effective Current (A)	20.5	11.3
	AC Input Current (A)	30.5	21.5
	AC Input effective Current (A)	18.0	10.7
	DC Welding Current (A)	10~140	10~200
	AC Welding Current (A)	10~140	10~200
	Welding Voltage (V)	10.4~15.6	10.4~18.8
MMA	DC Input Current (A)	34.9	30.8
	DC Input effective Current (A)	20.6	15.4
	AC Input Current (A)	33.8	31.4
	AC Input effective Current (A)	20.0	15.7
	DC Welding Current (A)	10~110	10~200
	AC Welding Current (A)	10~110	10~200
	Welding Voltage (V)	20.4~24.4	20.4~28

Duty Cycle (DC)

	110V input			230V input		
	30%	60%	100%	25%	60%	100%
MIG	140A	105A	80A	200A	160A	140A
TIG	45%	60%	100%	25%	60%	100%
	140A	125A	100A	200A	150A	120A
MMA	35%	60%	100%	25%	60%	100%
	110A	90A	70A	200A	140A	120A

Duty Cycle (AC)

	110V input			230V input		
	35%	60%	100%	25%	60%	100%
TIG	140A	120A	90A	200A	140A	115A
MMA	35%	60%	100%	25%	60%	100%
	110A	85A	70A	200A	140A	115A

4.0 Installation

Read entire installation section before starting installation.

SAFETY PRECAUTIONS

- **ELECTRIC SHOCK** can kill.
- Only qualified personnel should perform this installation.
- Only personnel that have read and understood the Operating Manual should install and operate this equipment.
- Machine must be grounded per any national, local or other applicable electrical regulations.
- The MIG power switch is to be in the OFF position when installing work cable and torch and when connecting other equipment.

4.1 Location

Position the power source so that its cooling air inlets and outlets are not obstructed.

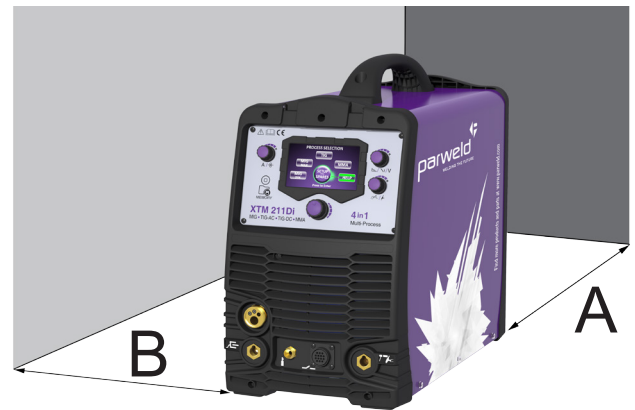

A. 100mm (4in.) minimum

B. 100mm (4in.) minimum

4.2 Input and Grounding Connection

WARNING

Before starting the installation, check that your power supply is adequate for the voltage, amperage, phase, and frequency specified on the Machine nameplate.

The 110/230 volt 50 Hz machine is supplied with a 3m input cable and without plug, ensure that you connect a plug that is suitably rated for the power draw of the machine and the environmental location.

Have a qualified electrician connect the input plug.

5.0 Description of Controls and Torch Connections



1. Power Switch for Incoming Mains
2. QF Incoming Gas Connection MIG
3. QF Incoming Gas Connection TIG

4. MIG Torch Connector
5. Work Lead Connector
6. TIG Torch / Electrode Holder Socket
7. Wire Spool Holder
8. Wire Feed Unit
9. Multifunction Control Knob



10. Amperage / Wire Speed Adjustment
11. Voltage / Downslope / Arc Force Adjustment
12. Inductance / Post Gas Control
13. Digital Display
14. TIG Torch Trigger Connector
15. TIG Torch Gas Connector

6.0 Operation

6.1 Use of Controls

Multifunction Control Knob.

Rotate and Select

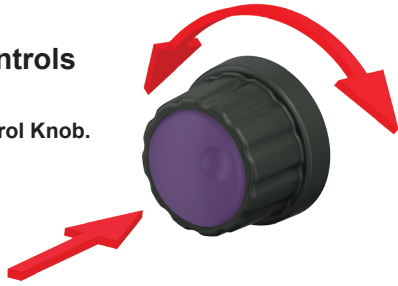

Rotate left or right to highlight an option on the screen.

Press to select

Press and hold to step back in menu tree

Short press at end of menu returns to start menu

6.2 Language of Operation

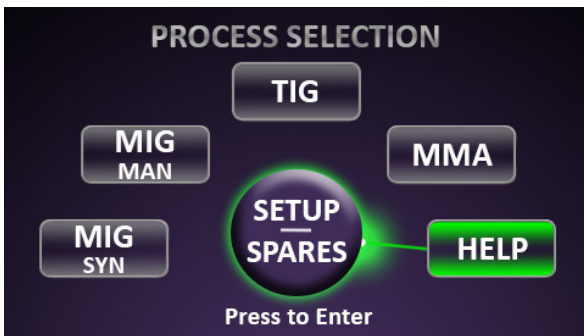

Short Press (1 sec) to return to start menu

6.3 Process Selection

MIG SYN Synergic MIG Welding Allows Simple and Rapid Setup.



MIG MAN Manual MIG Welding Setup



TIG Synergic TIG Welding Setup



MMA Synergic MMA Welding Setup



6.4 MIG Welding Preparing the Machine

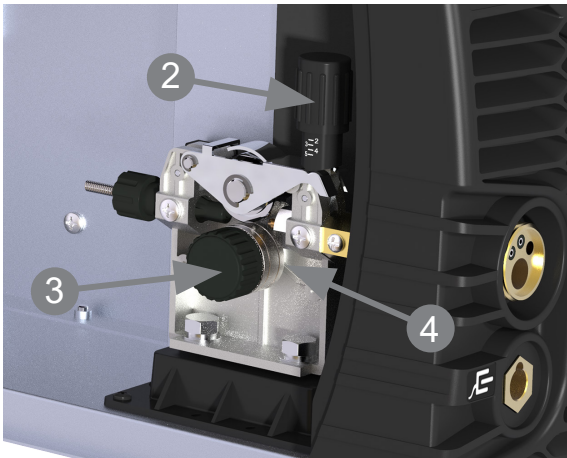

1. Open the Wire Drive Compartment Door by lifting the 2 finger catches on the side panel.
2. Release the pressure on the idle roll by swinging the adjustable pressure arm down towards the front of the machine. Lift the idle roll assembly and allow it to sit in an upright position.
3. Unscrew the plastic knob retaining the lower grooved feed roll and slide off the feed roll.
4. Ensure the wire size marked on the side of the feed roll matches the wire size to be used.
5. Replace the drive in reverse of the above procedure ensuring the wire size to be used is marked on the outward facing side of the roller as it is refitted.

Note: Be sure that the torch liner and contact tip are also sized to match the selected wire size.

Welding Wire Installation

1. Set the spool holder for 100mm or 200mm spool.
2. Position the wire spool so that it will rotate in a direction when feeding so as to be de-reeled from the bottom of the coil.

100mm (4in.)

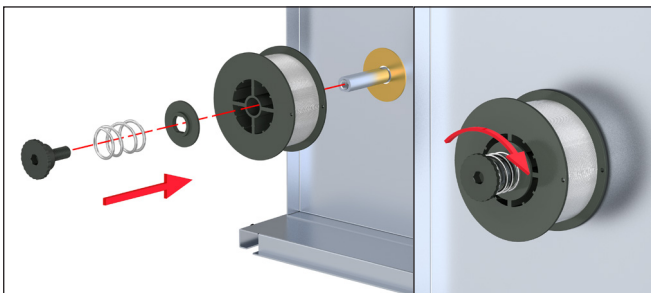

200mm (8in.) 300mm (12in.)

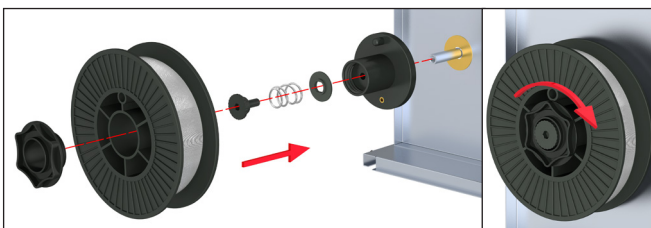

Note: There is a friction brake on the reel hub assembly to prevent the wire spool over running when welding stops; ensure this is slackened to the minimum setting. It can be adjusted by means of the nut visible when the plastic hand nut is removed.

1. Turn the Spool until the free end of the electrode is accessible. While securely holding the electrode, cut off the bent end and straighten the first six inches. (If the electrode is not properly straightened, it may not feed properly through the wire drive system). Manually feed the wire from the wire reel and through the wire guide and then over the top of the wire feed roller (ensure the pressure arm is in its raised position).
2. Continue to feed the wire through the outlet guide until 20mm of wire is protruding from the front of the machine torch connector.
3. Reposition the adjustable pressure arm to its original position to apply pressure. Adjust pressure as necessary.

Note: The pressure arm should be adjusted in order to give the minimum amount of pressure on the wire to allow reliable feeding.

MIG Torch Installation

Your Parweld MIG/MAG Welding Torch has been supplied ready to weld. It has been supplied with the standard consumables denoted in the product brochure.

To connect the torch to the power source:

1. Remove the contact tip.
2. Inch the wire from the exit of the wire guide on the feed unit as Figure 1. Ensure that it does not short out on any machine panels.
3. Carefully slide the electrode wire into the torch liner and slowly locate the torch gun plug body into the feed unit central connector and tighten the gun plug nut as Figure 2

Fig 1

Fig 2

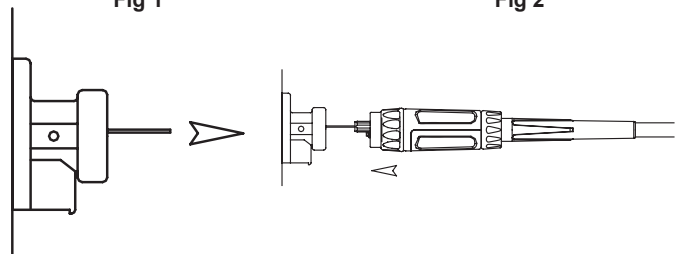

Note: To aid the initial location of a new torch and to prevent damage to the gas nipple O-Ring a very light application of grease to the O-Ring is beneficial.

4. Keeping the torch as straight as possible, use the power source inch facility or torch trigger to feed the electrode wire 50mm from the end of the torch.
5. Once the electrode wire has stopped, refit the contact tip and gas nozzle.
6. Trim the electrode wire to within 5mm of the face of the nozzle; this will facilitate jolt free arc initiation.

Note: Check that drive rolls, and torch parts are correct for the wire size and type being used.

7. The optimum idle roll pressure varies with type of wire, wire diameter, surface conditions, lubrication and hardness. As a general rule, hard wires may require greater pressure, and soft or aluminium wire, may require less pressure than the factory setting. The optimum idle roll setting can be determined as detailed on the following page.

MIG Torch Installation (continued)

8. Press end of gun against a solid object that is electrically isolated from the welder output and press the gun trigger for several seconds.
9. If the wire "bird nests", jams or breaks at the drive roll, the idle roll pressure is too great. Back the adjustment knob out 1/2 turn, run new wire. If the only result was drive roll slippage, loosen the Hand nut on the central connector and pull the gun forward about 6" (15cm) away from the power source. There should be a slight waviness in the exposed wire. If there is not waviness, the pressure is too low. Tighten the adjustment knob 1/4 turn, reinstall the gun cable and repeat the above steps.
10. When triggering, the electrode and drive mechanism are electrically "LIVE" relative to work and ground and remain "LIVE" several seconds after the gun trigger is released.

Burn back

Adjusted on screen from the Help Menu.



Soft start

The machine has a pre-set soft start system.

7.0 Setting the Machine for Welding

7.1 MIG Torch Selection

Select the HELP menu from the main Process Selection screen and follow the screen prompts as follows.



7.2 MIG SYN Synergic MIG Welding Allows Simple and Rapid Setup.

Follow the screen prompts to complete the machine setup. Example setting.

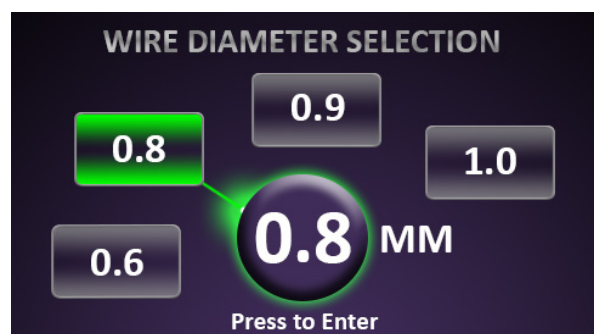

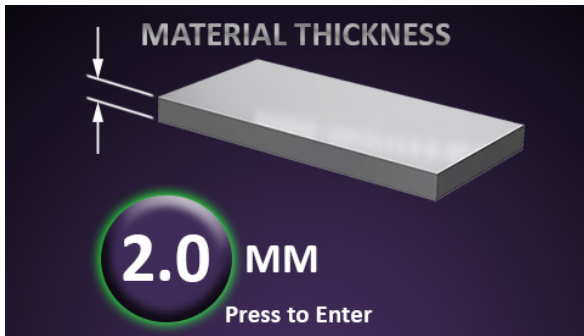
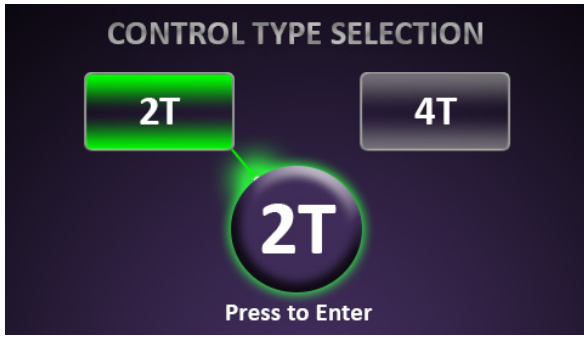

Operating screen (MIG SYN)

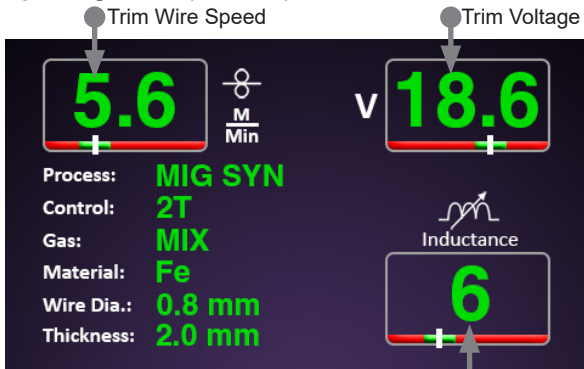

Adjust Inductance (short circuit current)

7.3 MIG MAN Manual MIG welding setup

Follow the screen prompts to complete the machine setup. Example setting.

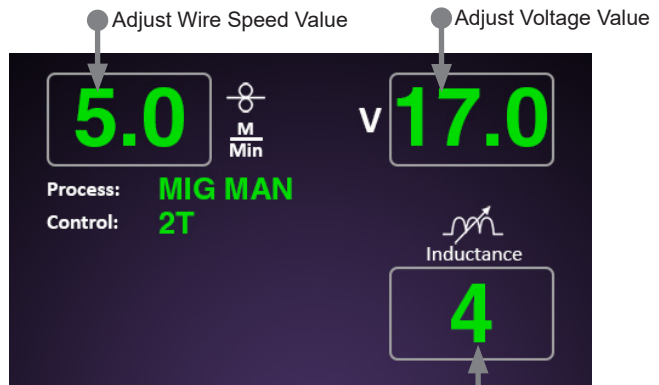

In manual mode you can adjust the parameters using the controls indicated.

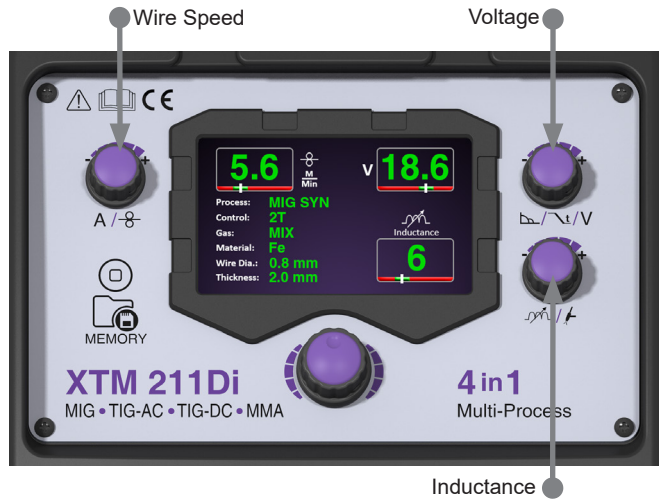

7.4 Remote Control MIG Torch

Allows remote adjustment of the Voltage and wire speed from the torch handle when in the welding screen.

MIG SYN

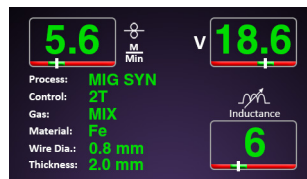

MIG MAN



Adjust by Pressing Torch Buttons on the Handle.

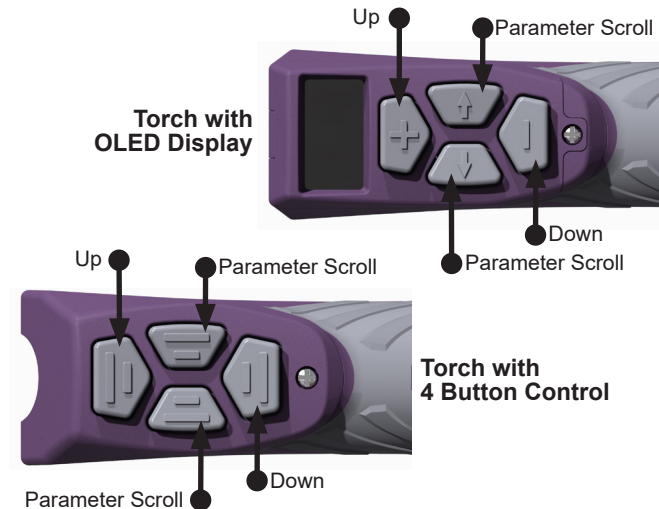

7.5 MIG Welding Procedure

1. Position wire over joint. The end of the wire may be lightly touching the work.
2. Lower welding helmet, operate torch trigger, and begin welding. Hold the torch so the contact tip to work distance is about 3/8" (10 mm).
3. To stop welding, release the torch trigger and then pull the torch away from the work after the arc goes out.
4. When no more welding is to be done, close valve on gas cylinder (if used), momentarily operate torch trigger to release gas pressure and turn off the machine.

7.6 MMA Welding

Follow the screen prompts to complete the machine setup. Example setting.

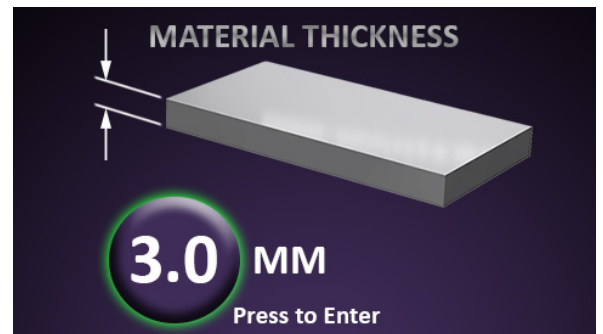
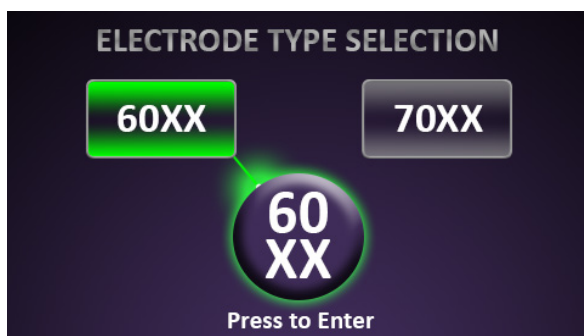
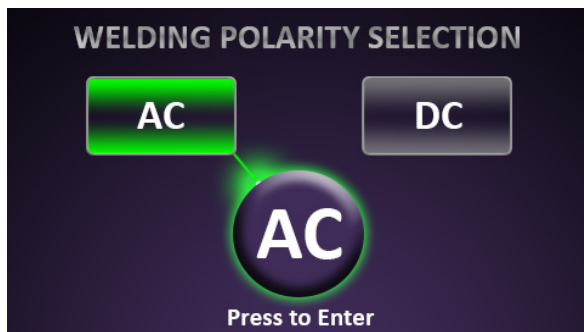

Adjust Amperage Value

Adjust Arcforce Value

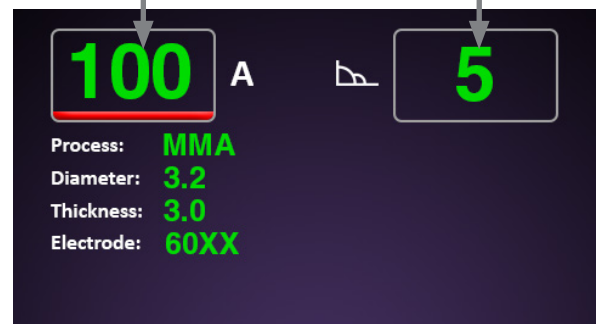

7.7 TIG Welding

Follow the screen prompts to complete the machine set up.

7.7.1 TIG Torch Selection

Select the HELP menu from the main Process Selection screen and follow the screen prompts as follows.



7.7.2 TIG Torch Installation

See page 7 for Torch Connections to the Machine.

7.7.3 TIG Welding Set Up

Follow the screen prompts to complete the machine set up.



Manual Set allows adjustment of all weld parameters.

Auto Set allows rapid setting of the machine based on material type and thickness, with HF starting.

Auto Set Example

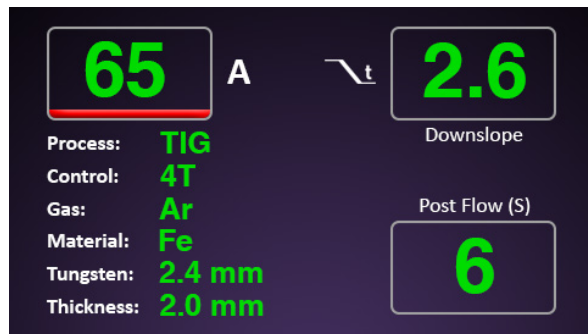
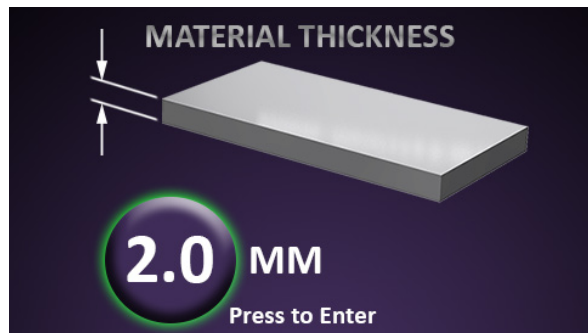
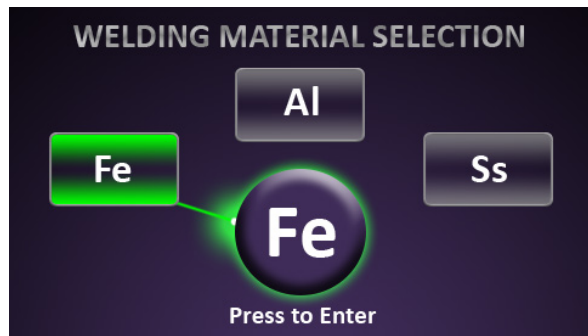
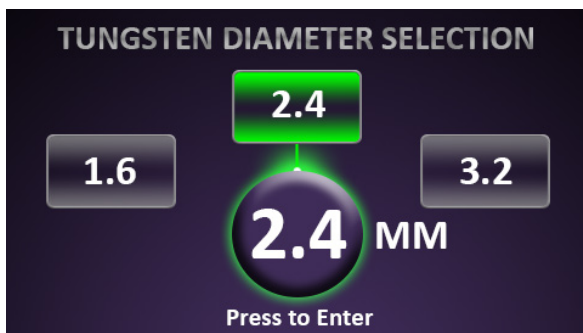
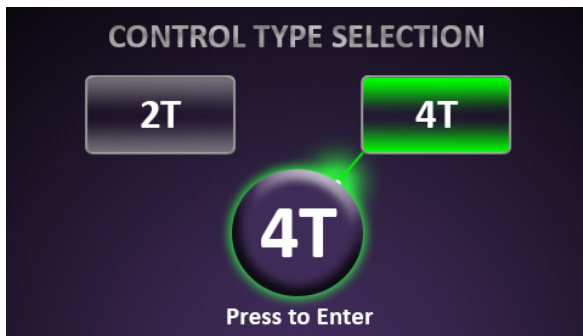
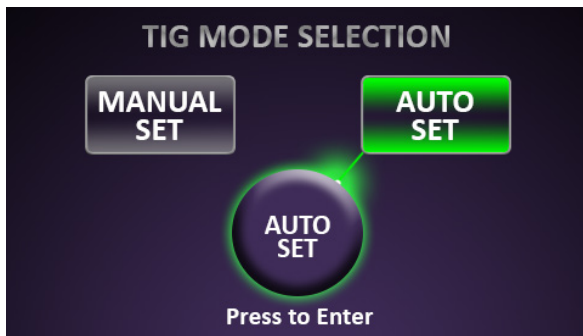

Adjust downslope and post flow to user preference using the knobs on the right of the screen.

Manual Set Example

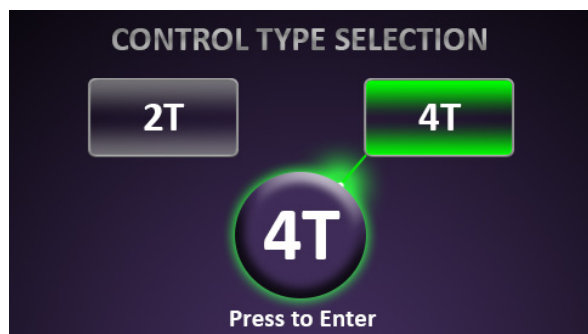
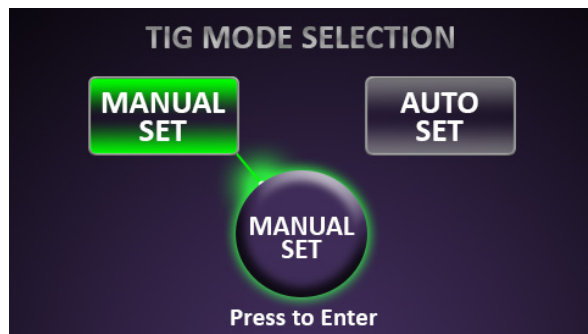

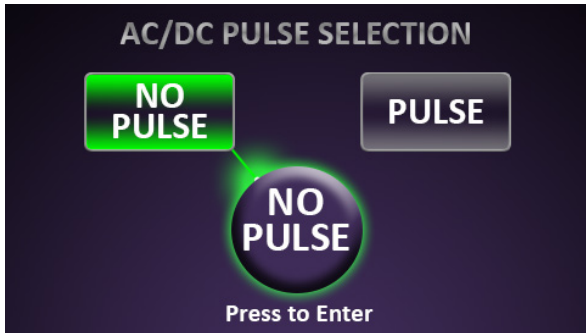
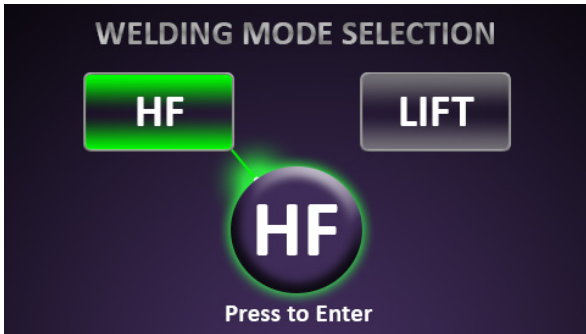
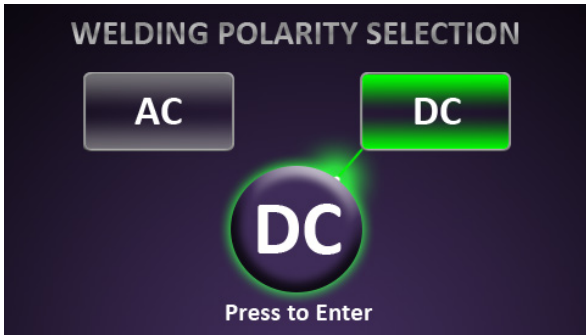

Welding Screens

DC Without Pulse.

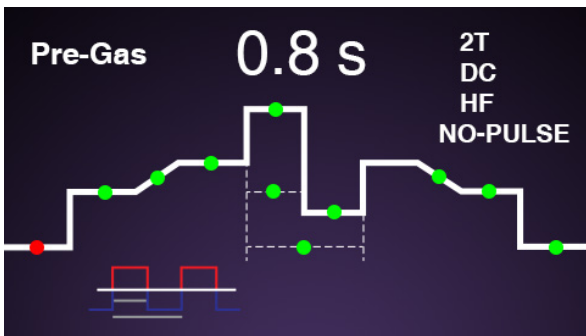

DC With Pulse.

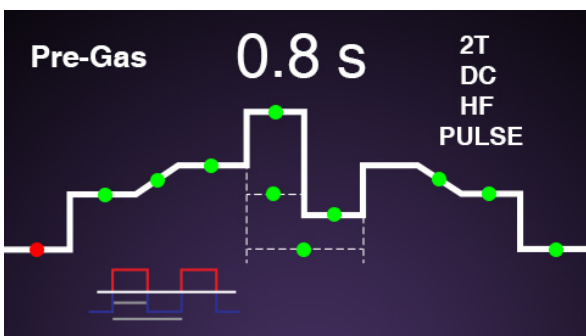

AC Without Pulse.

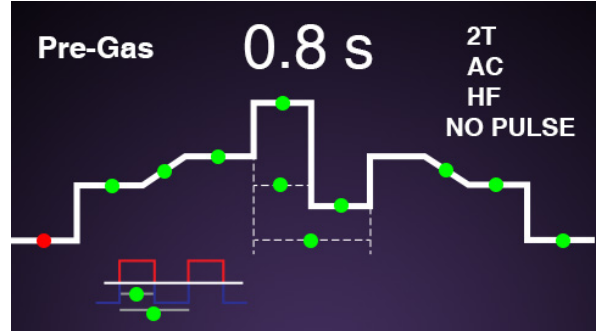

AC With Pulse.

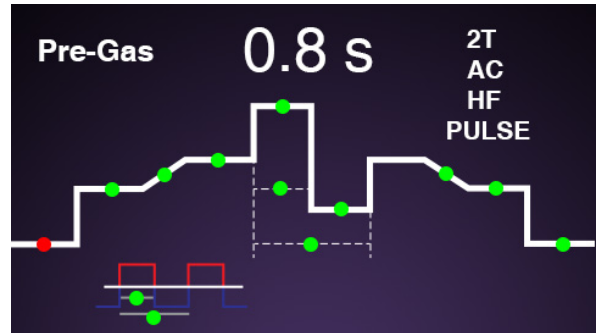

To Select and adjust Pre-Gas, Slope Up, Welding Current, Slope Down, or Post Gas do the following:

- Rotate control knob to move red dot
- Press to select (flashing)
- Rotate control knob to adjust
- Press control knob to deselect (stops flashing)

TIG Welding Trigger Operation

-2T -4T

This toggles between 2 step and 4 step operation of the torch trigger. In 2 step mode the trigger should be pressed and held down until the end of the weld. In 4 step mode (lower led) the trigger is pressed and released to start and pressed and released to finish the weld. In order to TIG weld one of these functions must be illuminated. Not all functions are available in 2T mode.

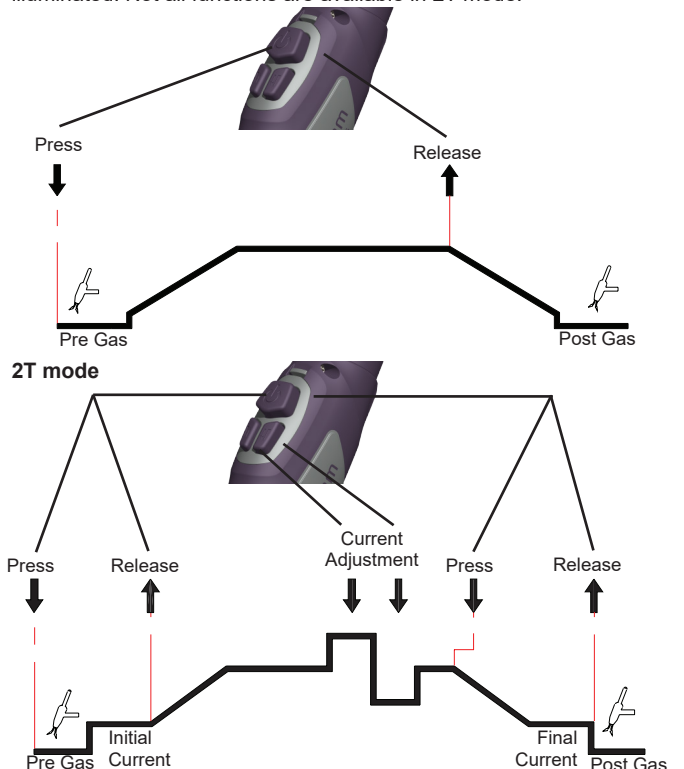

Step Current, 4T mode

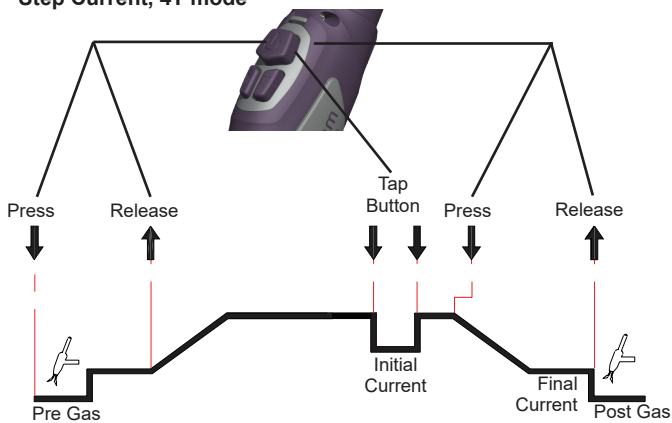

Type	Application	Colour
Ceriated 2%	DC welding of mild steel, Stainless steel, Copper AC welding of aluminium, magnesium and their alloys	Grey
Zirconiated	AC welding of aluminium, magnesium and their alloys	White

Guide for selecting filler wire diameter

Filler wire diameter	Current range
1/16" (1.6 mm)	20 - 90
3/32" (2.4 mm)	65 - 115
1/8" (3.2 mm)	100 - 165
3/16" (4.8 mm)	200-350

The filler wire diameter specified is a guide only, other diameter wires may be used according to the welding application.

Shielding gas selection

Alloy	Shielding gas
Aluminium & alloys	Pure Argon
Carbon steel	Pure Argon
Stainless steel	Pure Argon

Nickel alloy	Pure Argon
Copper	Pure Argon
Titanium	Pure Argon

7.7.4 TIG Welding Guide

Torch starting in Lift TIG mode

Ensure the gas supply is switched on to the machine. Briefly contact the tip of the tungsten electrode down onto the work piece with the torch at around 70° from vertical. Depress the trigger to start the gas flow and switch on the power, lift the torch up from the work piece to draw out an arc. To prevent melting of the end of the tungsten the machine will increase the output current when it detects the rise in arc voltage as the tungsten is lifted from the work piece. At the end of the weld release the torch trigger and the power will slope down and switch off.

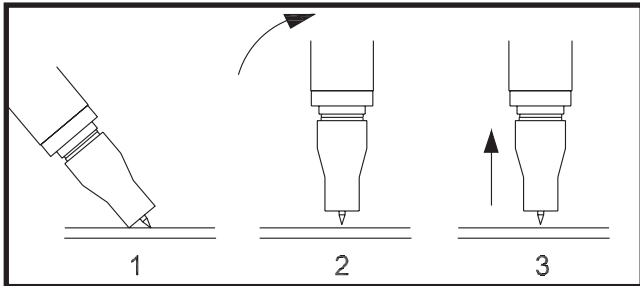

At the end of the weld release the trigger and allow the power and gas to switch off before moving the torch from the weld.

Torch starting in HF mode

Ensure the gas supply is switched on to the machine. Hold the torch with the tip of the tungsten approx 2-3 mm from the job. Depress the trigger to start the gas flow and switch on the power. At the end of the weld release the torch trigger and the power will slope down and switch off.

TIG welding guide ranges

Electrode diameter	AC current (amps)	DC current (amps)
0.040" (1.0mm)	15-30	20-60
1/16" (1.6mm)	60-120	75-150
3/32" (2.4mm)	100-180	150-250

Tungsten electrode types

Type	Application	Colour
Thoriated 2%	DC welding of mild steel, Stainless steel and Copper	Red

7.7.5 DC TIG welding (No Pulse)

Note:- shorting or dipping the electrode into the weld pool for more than 1 second will cause the machine to reduce the welding power to zero in order to protect the tungsten and minimise contamination.

- 1) Connect the torch to the TIG torch socket and the gas hose to the gas outlet.
- 2) Connect the trigger control plug on the torch to the trigger socket.
- 3) Connect the Earth lead to the Earth socket.
- 4) Set the process mode to 2T or 4T if you prefer a latching trigger action. (Note in 4T position you must press and release to start the process and press and release again to stop the process).

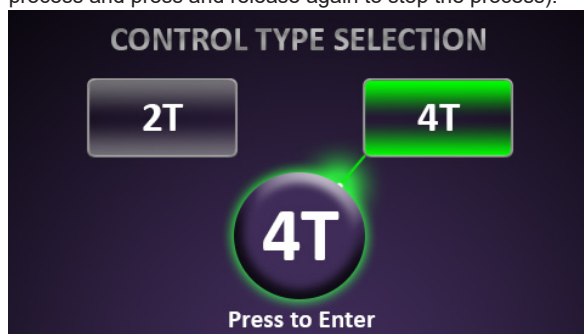

5) Select DC output.

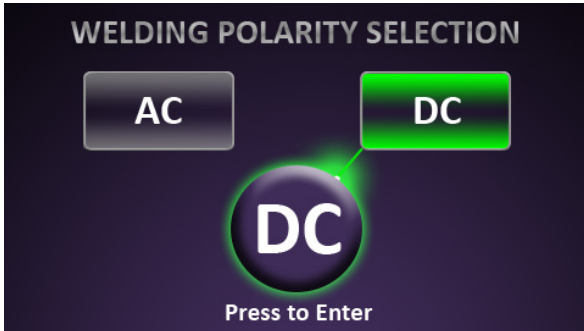

6) Select HF start

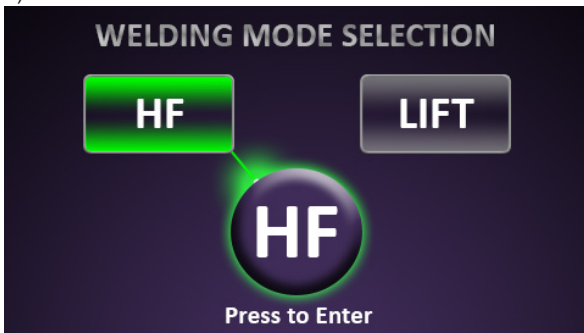

7) Select No Pulse.

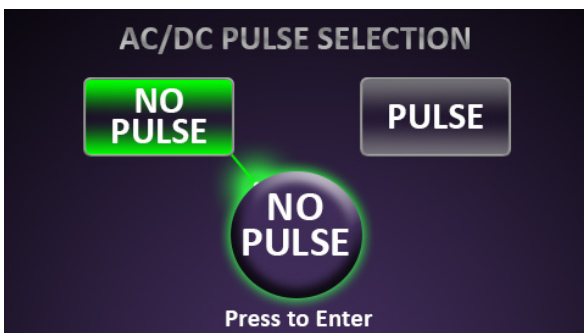

8) Rotate the control knob to move the illuminated LED to the gas pre-flow position (A).

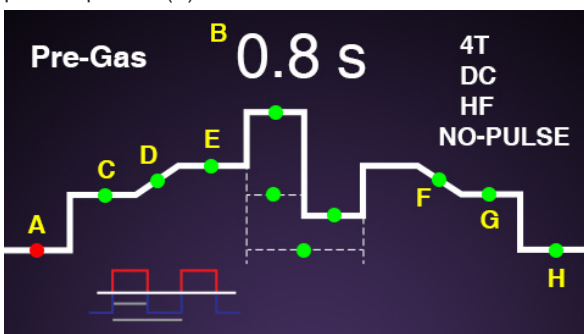

9) Press the control knob to select the parameter. The red LED will now flash. Adjust the value by rotating the control knob. This can be adjusted from 0.1 to 0.3 seconds. The value is displayed on the digital display (B) Press the control knob again to accept the setting.

10) Rotate the control knob to move the LED to the initial current (C) This can be adjusted from 5 to 100% of the main welding current. The value is displayed on the digital display (B). 50% is a good initial setting. **Note this function only operates in 4T switch mode.**

11) Rotate the control knob to move the LED to the slope up time (D) This can be adjusted from 0 to 10s. The value is displayed on the digital display (B). 2s is a good initial setting.

12) Rotate the control knob to move the LED to the main welding current (E) This can be adjusted from 5 to 200A. The value is displayed on the digital (B). Refer to the TIG welding guide for a recommended welding current.

13) Rotate the control knob to move the LED to the slope down time (F) This can be adjusted from 0 to 10s. The value is displayed on the digital display (B). 2s is a good initial setting.

14) Rotate the control knob to move the LED to the final current (G) This can be adjusted from 5 to 100% of the main welding current. The value is displayed on the digital display (B). 10% is a good initial setting. **Note this function only operates in 4T switch mode**

15) Rotate the control knob to move the LED to the Post Gas time (H). This can be adjusted from 0.1 to 10s. The value is displayed on the digital display (B). 3s is a good initial setting.

You are now ready to weld. These settings are a guide and you should adjust to suit the job you are welding. If you are unfamiliar with the machine try to adjust only one parameter at a time so you become familiar with its effect.

7.7.6 AC TIG welding (No Pulse)

Note:- shorting or dipping the electrode into the weld pool for more than 1 second will cause the machine to reduce the welding power to zero in order to protect the tungsten and minimise contamination.

1) Connect the torch to the TIG torch socket and the gas hose to the gas outlet.

2) Connect the trigger control plug on the torch to the trigger socket.

3) Connect the Earth lead to the Earth socket.

4) Set the process mode to 2T or 4T if you prefer a latching trigger action. (Note in 4T position you must press and release to start the process and press and release again to stop the process).

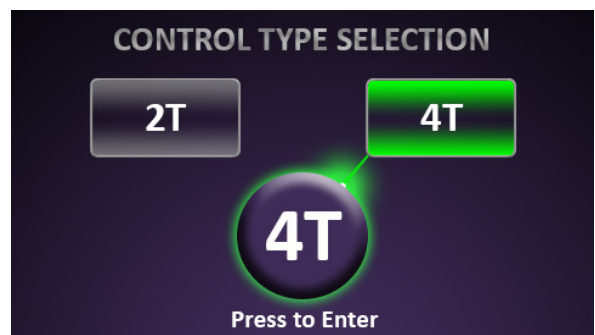

5) Select AC output.

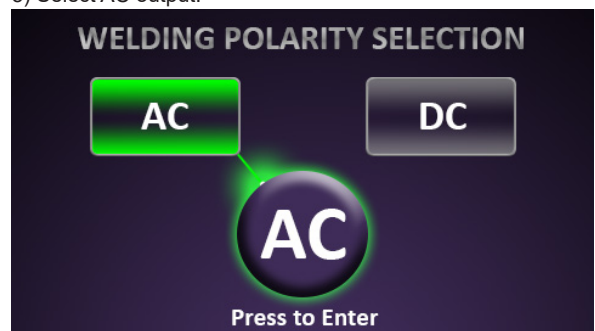

6) Select HF start.

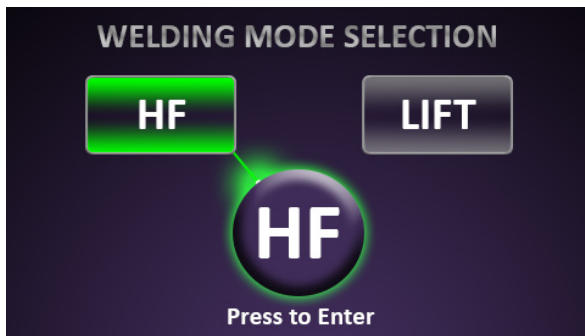

7) Select No Pulse.

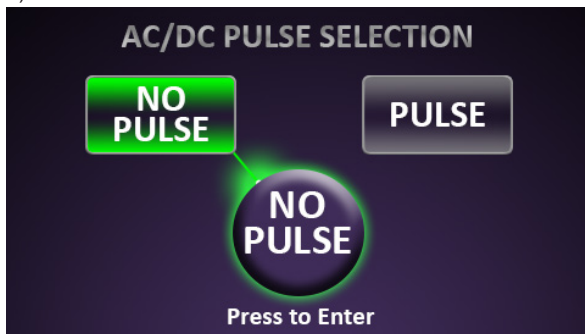

8) Rotate the control knob to move the illuminated LED to the gas pre-flow position (A).

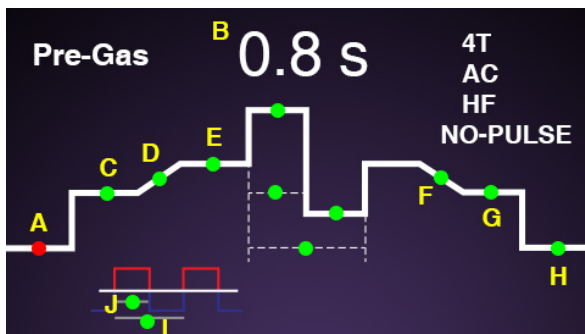

9) Press the control knob to select the parameter. The red LED will now flash. Adjust the value by rotating the control knob. This can be adjusted from 0.1 to 0.3 seconds. The value is displayed on the digital display (B) Press the control knob again to accept the setting.

10) Rotate the control knob to move the LED to the initial current (C) This can be adjusted from 5 to 100% of the main welding current. The value is displayed on the digital display (B). 50% is a good initial setting. **Note this function only operates in 4T switch mode.**

11) Rotate the control knob to move the LED to the slope up time (D) This can be adjusted from 0 to 10s. The value is displayed on the digital display (B). 2s is a good initial setting.

12) Rotate the control knob to move the LED to the main welding current (E) This can be adjusted from 5 to 200A. The value is displayed on the digital (B). Refer to the TIG welding guide for a recommended welding current.

13) Rotate the control knob to move the LED to the slope down time (F) This can be adjusted from 0 to 10s. The value is displayed on the digital display (B). 2s is a good initial setting.

14) Rotate the control knob to move the LED to the final current (G) This can be adjusted from 5 to 100% of the main welding current. The value is displayed on the digital display (B). 10% is a good initial setting. **Note this function only operates in 4T switch mode.**

15) Rotate the control knob to move the LED to the Post Gas time (H). This can be adjusted from 0.1 to 10s. The value is displayed on the digital display (B). 3s is a good initial setting.

16) Rotate the control knob to move the LED to the AC frequency (I) This can be adjusted from 25 to 200Hz dependant on the welding amperage. The value is displayed on the digital display (B). 60hz is a good initial setting. Increasing the frequency has the effect of stiffening and focussing the arc making it good for welding close to threads or for crater filling.

Note the maximum frequency available depends upon the welding amperage selected.

<50A	50 to 250Hz
50-100A	50-200Hz
100-150A	Max 150Hz
150-200A	Max 100Hz

17) Rotate the control knob to move the LED to the AC balance (J) This can be adjusted from 15 to 50% . The value is displayed on the digital display (B). 15% is a good initial setting. Increasing the percentage has the effect of increasing the time the arc spends in the electrode positive state which gives a greater cleaning effect on the material but will reduce weld speed. For good clean material you should be able to keep the cleaning percentage set at 15 to 20%

You are now ready to weld. The above settings are a guide and you should adjust to suit the job you are welding. If you are unfamiliar with the machine try to adjust only one parameter at a time so you become familiar with its effect.

7.7.7 TIG welding (With Pulse)

It is possible to use the pulse function with both AC and DC TIG welding. Power Pulsing can give significant advantages on thinner material to control heat and penetration.

1) Follow the setup as previously described for AC or DC TIG welding. At the Pulse Selection menu select Pulse.

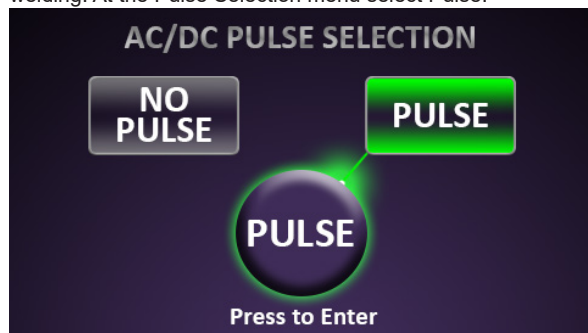

3) Press the control knob to move the LED to the Peak current (K) This can be adjusted from 5 to 200A (10-200A for AC welding) dependant on the welding amperage. The value is displayed on the digital display (B). Peak current is the maximum amperage that will be output.

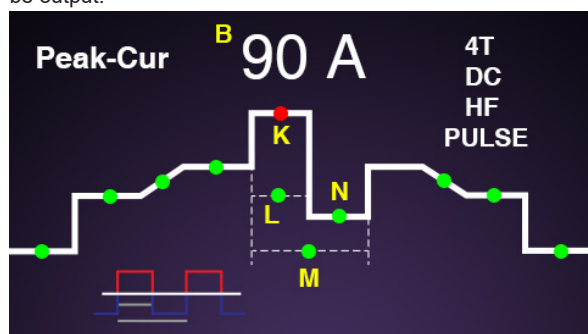

4) Rotate the control knob to move the LED to the Peak duration (L) This can be adjusted from 5 to 100% Peak duration is the percentage of time the peak current is on relative to the background current. 30% is a good starting point.

5) Rotate the control knob to move the LED to the Background current (N) This can be adjusted from 5 to 200A (10-200A for AC welding). The value is displayed on the digital display (B). Background current is the minimum amperage that will be output. It cannot be higher than the peak current and generally will be set withing 50 to 70% Amps of the peak current.

6) Rotate the control knob to move the LED to the Pulse Frequency (M) This can be adjusted from 0.5 to 200Hz. The value is displayed on the digital display (B). Pulse Frequency is the number of pulses per second generally a range of 50 to 150 hz will be used with 100Hz being a good base setting.

30-40Hz will help agitate the weld puddle and allow you to weld at a lower amperage than without pulse.

50-150Hz really stiffen the arc and let you pinpoint the arc more than without pulse.

0.5-10Hz reduce heat input the most.

The selected amperage and the consistency of travel speed can negate some of the effects of Power pulsing.

7.8 Saving to Memory

In any welding screen press the memory button.



Memory button

From here you can see the last weld setting used (O) or select one of the memory locations (P) to save the job to.

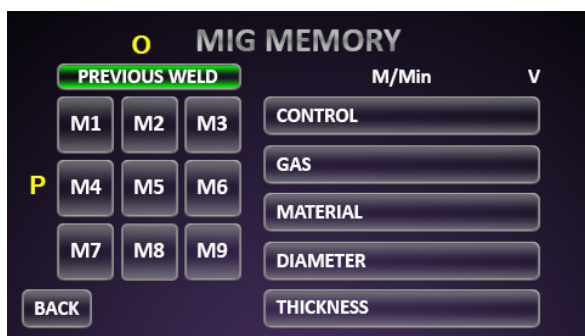

After selecting a memory location, the following screen loads and gives the option to save to memory.

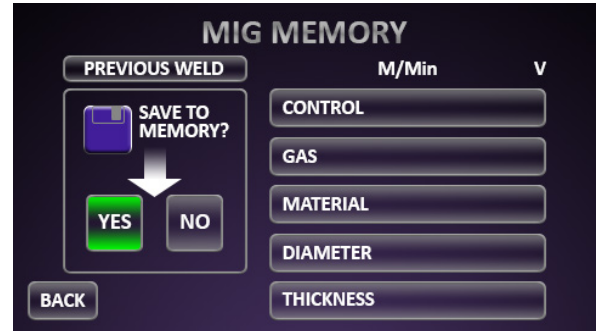

To recall from memory location, from main menu, press the memory button.



Memory button

Select job to recall by rotating the control knob to the required memory location and pressing the knob to select.

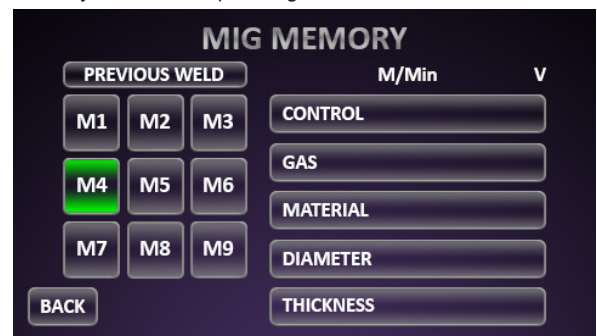

7.9 Process Switch

The XTM211Di allows instant swapping between the TIG and MIG processes which is ideal for pipe applications or multi process workshops.

Connect the MIG and TIG torches as previously described. Ensure both gas types are connected to the rear of the machine.

Set the machine from the main menu for the MIG and TIG parameters as required.

Switching the process. Press the torch trigger briefly to select the process.

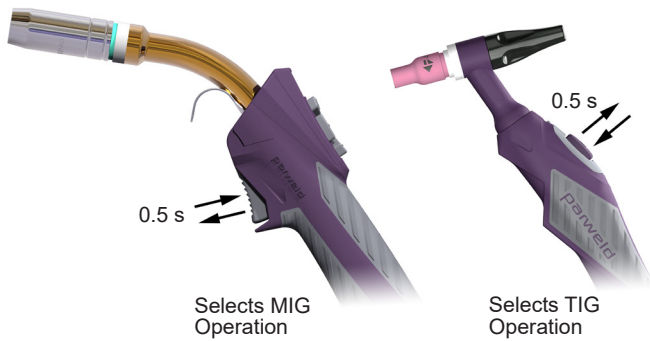

Please note this machine uses auto polarity switching so there is no need to change the work lead connections on the front of the machine.

8.0 Fault Finding

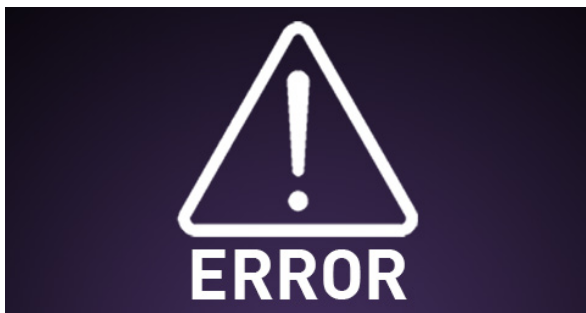

- If error message is displayed allow machine to cool with power off for 10 minutes.
- If error remains switch off and on again.
- Reduce welding current to prevent over current condition.
- If error remains contact your local service centre.

8.1 MIG Welding Problems

Problem	Cause/Corrective Action
Porosity - small cavities or holes resulting from gas pockets in weld metal.	<p>Inadequate shielding gas coverage. Check for proper gas flow rate.</p> <p>Remove spatter from gun nozzle.</p> <p>Check gas hoses for leaks.</p> <p>Eliminate drafts near welding arc.</p> <p>Place nozzle 6-13 mm from work piece and hold gun near bead at end of weld until molten metal solidifies.</p> <p>Wrong gas. Use welding grade shielding gas; change to different gas.</p> <p>Dirty welding wire. Use clean, dry welding wire. Eliminate pickup of oil or lubricant on welding wire from feeder or liner.</p> <p>Work piece dirty. Remove all grease, oil, moisture, rust, paint, coatings, and dirt from work surface before welding. Use a more highly deoxidizing welding wire (contact supplier).</p> <p>Welding wire extends too far out of nozzle.</p> <p>Be sure welding wire extends not more than 13 mm beyond nozzle.</p>
Incomplete fusion to base metal.	<p>Work piece dirty. Remove all grease, oil, moisture, rust, paint, coatings, and dirt from work surface before welding.</p> <p>Insufficient heat input. Select higher voltage range and/or adjust wire feed speed.</p> <p>Improper welding technique. Place stringer bead in proper locations at joint during welding.</p> <p>Adjust work angle or widen groove to access bottom during welding.</p> <p>Momentarily hold arc on groove side walls when using weaving technique.</p> <p>Keep arc on leading edge of weld puddle. Use correct gun angle of 0 to 15 degrees.</p>

8.1 MIG Welding Problems (continued)

Problem	Cause/Corrective Action
Excessive Penetration - weld metal melting through base metal and hanging underneath weld.	Excessive heat input. Select lower voltage range and reduce wire feed speed. Increase travel speed.
Lack of Penetration - shallow fusion between weld metal and base metal.	Improper joint preparation. Material too thick. Joint preparation and design must provide access to bottom of groove while maintaining proper welding wire extension and arc characteristics. Improper weld technique. Maintain normal gun angle of 0 to 15 degrees to achieve maximum penetration. Keep arc on leading edge of weld puddle. Ensure welding wire extends not more than 13 mm beyond nozzle. Insufficient heat input. Select higher wire feed speed and/or select higher voltage range. Reduce travel speed.
Burn-Through - weld metal melting completely through base metal resulting in holes where no metal remains.	Excessive heat input. Select lower voltage range and reduce wire feed speed. Increase and/or maintain steady travel speed.
Excessive Spatter - scattering of molten metal particles that cool to solid form near weld bead.	Wire feed speed too high. Select lower wire feed speed. Voltage too high. Select lower voltage range. Electrode extension (stick out) too long. Use shorter electrode extension (stick out). Work piece dirty. Remove all grease, oil, moisture, rust, paint, undercoating, and dirt from work surface before welding. Insufficient shielding gas at welding arc. Increase flow of shielding gas at regulator/flow meter and/or prevent drafts near welding arc. Dirty welding wire. Use clean, dry welding wire. Eliminate pickup of oil or lubricant on welding wire from feeder or liner.
Wire feed unit operates but no gas flow .	Gas cylinder empty Gas regulator closed Faulty solenoid Restriction in torch cables

Problem	Cause/Corrective Action
Wire feed unit operates, but does not feed	Insufficient drive roll pressure Incorrect drive rolls Excessive wire spool brake tension Incorrect liner Blocked liner Bird nesting Burn back
Bird nesting	Excessive feed roll pressure Incorrect or blocked liner Incorrect contact tip size Contact tip overheating Restriction in torch cable Misaligned drive rolls or wire guides Excessive cable kinkage
Burn back	Improper voltage setting Improper stick out Erratic wire feed Incorrect or blocked liner Contact tip overheating Excessive cable kinking
Erratic Wire Feeding or Arc	Improper drive roll tension Improper drive roll size Worn drive rolls Incorrect or blocked liner Incorrect wire guide size Misaligned drive rolls or wire guide Gaps at liner or wire guide junctions Incorrect contact tip size Contact Tip overheating Spatter adhesion on exit geometry of tip bore Excessive cable kinkage Poor earth or cable connections Weld joint area dirty

8.2 MMA Welding Problems

Description	Possible cause	Remedy
Gas pockets or voids in weld metal (porosity)	(a) Electrodes are damp (b) Welding current is too high. (c) Surface impurities such as oil, grease, paint, etc	(a) Dry electrodes before use (b) Reduce welding current (c) Clean joint before welding
Crack occurring in weld metal soon after solidification.	(a) Rigidity of joint. (b) Insufficient throat thickness. (c) Cooling rate is too high.	(a) Redesign to relieve weld joint of severe stresses or use crack resistance electrodes. (b) Travel slightly slower to allow greater build up in throat. (c) Preheat plate and cool slowly.
A gap is left by failure of the weld metal to fill the root of the weld	(a) Welding current is too low. (b) Electrode too large for joint. (c) Insufficient gap (d) Incorrect sequence	(a) Increase welding current (b) Use smaller diameter electrode. (c) Allow wider gap (d) Use correct build-up sequence
Portions of the weld run do not fuse to the surface of the metal or edge of the joint.	(a) Small electrodes used on heavy cold plate (b) Welding current is too low (c) Wrong electrode angle (d) Travel speed of electrode is too high (e) Scale or dirt on joint surface	(a) Use larger electrodes and preheat the plate (b) Increase welding current (c) Adjust angle so the welding arc is directed more into the base metal (d) Reduce travel speed of electrode (e) Clean surface before welding.

Description	Possible cause	Remedy
Non-metallic particles are trapped in the weld metal (slag inclusion).	(a) Non-metallic particles may be trapped in undercut from previous run (b) Joint preparation too restricted (c) Irregular deposits allow slag to be trapped. (d) Lack of penetration with slag trapped beneath weld bead. (e) Rust or mill scale is preventing full fusion. (f) Wrong electrode for position in which welding is done.	(a) If bad undercut is present, clean slag out and cover with a run from a smaller diameter electrode. (b) Allow for adequate penetration and room for cleaning out the slag (c) If very bad, chip or grind out Irregularities (d) Use smaller electrode with sufficient current to give adequate penetration. (e) Use suitable tools to remove all slag from corners (f) Use electrodes designed for position in which welding is done, otherwise proper control of slag is difficult.

8.3 TIG Welding Problems

Weld quality is dependent on the selection of the correct consumables, maintenance of equipment and proper welding technique.

Description	Possible Cause	Remedy
Excessive bead build up or poor penetration or poor fusion at edges of weld	Welding current is too low	Increase weld current and/or faulty joint preparation
Weld bead too wide and flat or undercut at edges of weld or excessive burn through	Welding current is too high	Decrease weld current
Weld bead too small or insufficient penetration or ripples in bead are widely spaced apart	Travel speed too fast	Reduce travel speed
Weld bead too wide or excessive bead build up or excessive penetration in butt joint	Travel speed too slow	Increase travel speed
Uneven leg length in fillet joint	Wrong placement of filler rod	Re-position filler rod
Electrode melts when arc is struck	Electrode is connected to the '+' terminal	Connect the electrode to the '-' terminal
Dirty weld pool	(a) Electrode contaminated through contact with work piece or filler rod material (b) Gas contaminated with air	(a) Clean the electrode by grinding off the contaminates (b) Check gas lines for cuts and loose fitting or change gas cylinder
Electrode melts or oxidizes when an arc is struck	(a) No gas flowing to welding region (b) Torch is clogged with dust (c) Gas hose is cut (d) Gas passage contains impurities (e) Gas regulator is turned off (f) Torch valve is turned off (g) The electrode is too small for the welding current	(a) Check the gas lines for kinks or breaks and gas cylinder contents (b) Clean torch (c) Replace gas hose (d) Disconnect gas hose from torch then raise gas pressure to blow out impurities. (e) Turn on (f) Turn on (g) Increase electrode diameter or reduce the welding current
Poor weld finish	Inadequate shielding gas	Increase gas flow or check gas line for gas flow problems

Description	Possible Cause	Remedy
Arc flutters during TIG welding	(a) Tungsten electrode is too large for the welding current (b) Absence of oxides in the Weld pool.	(a) Select the right size electrode. Refer to basic TIG welding guide. (b) Refer basic TIG welding guide for ways to reduce arc flutter
Welding arc cannot be established	(a) Work clamp is not connected to the work piece or the work/torch leads are not connected to the machine (b) Torch lead is disconnected (c) Gas flow incorrectly set, cylinder empty or the torch valve is off	a) Connect the work clamp to the work piece or connect the work/torch leads to the right welding terminals. (b) Connect it to the '-' terminal. (c) Select the right flow rate, change cylinders or turn torch valve on.
Arc start is not smooth	(a) Tungsten electrode is too large for the welding current . (b) The wrong electrode is being used for the welding job. (c) Gas flow rate is too high. (d) Incorrect shielding gas is being used. (e) Poor work clamp connection to work piece	(a) Select the right size electrode (b) Select the right electrode type. Refer to basic TIG welding guide (c) Select the correct rate for the welding job. Refer to basic TIG welding guide (d) Select the right shielding gas. Refer to basic TIG welding guide (e) Improve connection to work piece

9.0 Control Torch Schematic



Pro-Grip Control® 250A

Air Cooled MIG Torch

230A CO₂, 200A Mixed Gas @ 60% Duty Cycle, EN60974-7 .030"-.045"/0.8mm to 1.2mm Wires

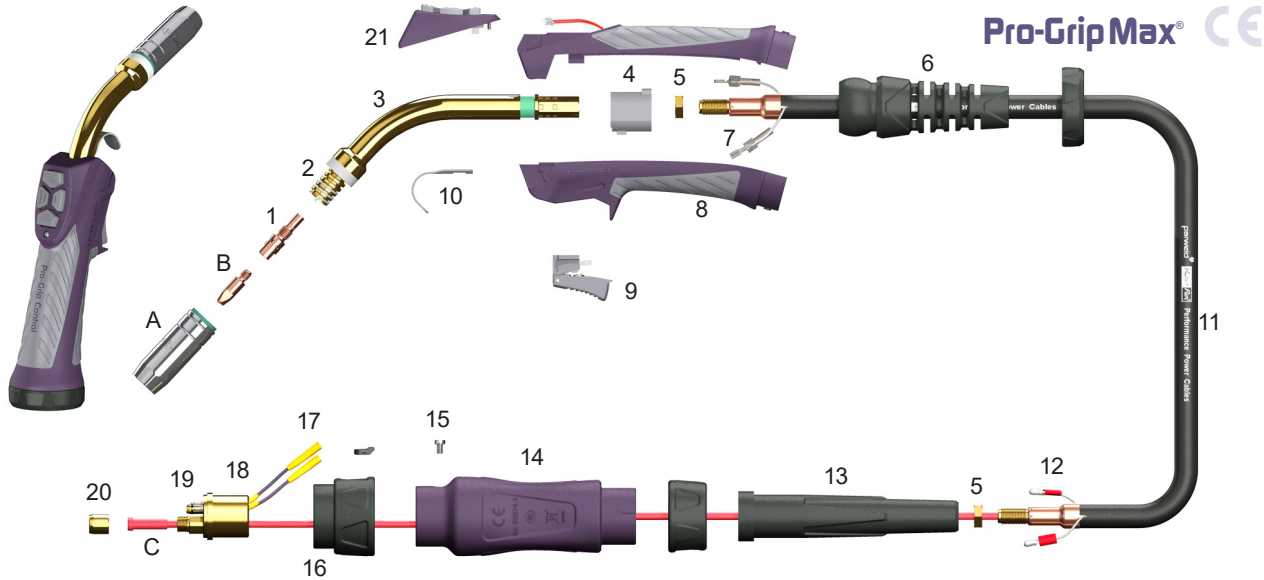

Models

Stock Code	Description
PRO2500-30ER4	Pro-Grip Control® Welding Torch c/w Euro Fitting x 3m
PRO2500-40ER4	Pro-Grip Control® Welding Torch c/w Euro Fitting x 4m
PRO2500-50ER4	Pro-Grip Control® Welding Torch c/w Euro Fitting x 5m

NB. For OLED Display version add a **D** to the end of the stock code.

Nozzles

Stock Code	Description
A B2507	Cylindrical Nozzle 5/7"/18mm Bore
B2508*	Conical Nozzle 19/32"/15mm Bore
B2509	Tapered Nozzle 15/32"/12mm Bore
B2510	Bottle Nozzle 19/32"/15mm Bore
B2511	Spot Welding Nozzle 5/7"/18mm Bore

Contact Tips

Stock Code	Description
B B2504-08	Contact Tip .030"/0.8mm M6 ECU
B2504-09	Contact Tip .035"/0.9mm M6 ECU
B2504-10*	Contact Tip .040"/1.0mm M6 ECU
B2504-12	Contact Tip .045"/1.2mm M6 ECU
B2505-08	Contact Tip .030"/0.8mm CuCrZr
B2505-09	Contact Tip .035"/0.9mm CuCrZr
B2505-10	Contact Tip .040"/1.0mm CuCrZr
B2505-12	Contact Tip .045"/1.2mm CuCrZr

Liners

Stock Code	Description
C B1535-30	Steel Liner .023"-.035"/0.6mm-0.9mm x 3m
B1535-40	Steel Liner .023"-.035"/0.6mm-0.9mm x 4m
B1535-50	Steel Liner .023"-.035"/0.6mm-0.9mm x 5m
B2524-30*	Steel Liner .040"-.045"/1.0mm-1.2mm x 3m
B2524-40*	Steel Liner .040"-.045"/1.0mm-1.2mm x 4m
B2524-50*	Steel Liner .040"-.045"/1.0mm-1.2mm x 5m
B1536-30	Teflon Liner .023"-.035"/0.6mm-0.9mm x 3m

Liners

* Denotes Standard Build

Stock Code	Description
B1536-40	Teflon Liner .023"-.035"/0.6mm-0.9mm x 4m
B1536-50	Teflon Liner .023"-.035"/0.6mm-0.9mm x 5m
B2513-30	Teflon Liner .040"-.045"/1.0mm-1.2mm x 3m
B2513-40	Teflon Liner .040"-.045"/1.0mm-1.2mm x 4m
B2513-50	Teflon Liner .040"-.045"/1.0mm-1.2mm x 5m

Components

Stock Code	Description
1 B2506*	Tip Adaptor M6
NI B2536	Tip Adaptor M8 (See M8 Tips)
2 B2502	Shroud Spring
3 B2501	Swan Neck
4 B1515/PG	Handle Location Body
5 B1505	Lock Nut
6 B8015	Cable Support c/w Knuckle Joint
7 B1521	Cable Terminal
8 B8514-MC4	Pro-Grip Control® Handle Kit c/w 4 Button Control
9 B8516	Pro-Grip Max® Trigger
10 B2517	Hanger Hook
11 B2503-30	Hyperflex™ Cable Assembly x 3m
B2503-40	Hyperflex™ Cable Assembly x 4m
B2503-50	Hyperflex™ Cable Assembly x 5m
12 B1522	Cable Terminal-Male
13 B2841	Cable Support
14 B1518	Gun Plug Housing c/w Nut
15 B1526	Gun Plug Screw
16 B1519	Gun Plug Nut c/w Insert
17 Spring Pin 2	Spring Pin Assembly
18 B1528	Gun Plug Body c/w Spring Pins
19 B1524	Gun Plug 'O' Ring
20 B1525	Liner Nut
21 PROMC4	4 Button MIG Control Module
PROMC4D	OLED Display MIG Control Module

10.0 Accessories

10.1 Feed Rolls



Part No.	Groove	Wire Sizes	Wires
DR2V0608	Plain V	0.6 - 0.8	Fe, Ss
DR2V0609	Plain V	0.6 - 0.9	Fe, Ss
DR2V0810	Plain V	0.8 - 1.0	Fe, Ss
DR2V1012	Plain V	1.0 - 1.2	Fe, Ss
DR2K0809	Knurled V	0.8 - 0.9	FC
DR2K1012	Knurled V	1.0 - 1.2	FC
DR2U0809	Plain U	0.8 - 0.9	Al
DR2U1012	Plain U	1.0 - 1.2	Al

10.2 MIG Torch Spares

Available on page 23 of this manual, and from the machine HELP menu.



10.3 Gas Equipment

Everyday Gas Regulators – 300 BAR

Single Stage

Features

Flow rate up to 96m³/h (3389 ft³/h).

- Full 300 bar capability.
- Outlet pressure indicated on the bonnet.
- Bottom entry design suited for top outlet cylinder valves.

Fittings

- Fitted with standard 3/8" BSP outlet.
- Fitted with 5/8" BSP inlet connections.



Stock Code	Description	Maximum Outlet Pressure
E700140	Argon Preset Regulator	3.0 Bar
E700141	Argon Indicator Regulator	3.0 Bar
E700113	1 Gauge Argon	30 lpm flow
E700123	2 Gauge Argon	30 lpm flow

Flow Meters

Features

- Designed from brass bar whilst the tube and cover are moulded from high quality polycarbonate to ensure high impact resistance and clarity.
- Calibrated to operate at an inlet pressure of 30PSI.
- Sensitive needle valve provides easy adjustment and the downward facing outlet connection eliminates hose kinking.



Fittings

- Fitted with standard 3/8" BSP inlet and outlet connections.

Stock Code	Description
706101	Flow Meter Mixed Gas 25 lpm (MIG)
706100	Flow Meter 0-12 lpm (TIG)

Gas flow Tester

- Designed to check gas flow at the front of MIG Torches.

Stock Code	Description
806001	Gas flow Tester



11.0 EC Declaration of Conformity

Hereby we declare that the machines as stated below

Type: XTM 211Di

Conform to the EC Directives:
Low Voltage Directive 2014/35/EEC
EMC Directive 2014/35/EEC
Harmonised European standard: EN/IEC 60974-1

This is to certify that the tested sample is in conformity with all provisions of the above detailed EU directives and product standards.



11.1 RoHS Compliance Declaration

Directive 2011/65/EU of the European Parliament
Amended 2015/863 and 2017/2102
Restriction of use of certain hazardous substances in electrical and electronic equipment

Type: XTM 211Di

The above listed products are certified to be compliant with the RoHS directive with all homogeneous component parts being controlled to ensure material contents as per the list below.

Cadmium 0.01% by weight
Lead 0.1% by weight
Mercury 0.1% by weight
Hexavalent chromium 0.1% by weight
Polybrominated biphenyl's (pbbs) 0.1% by weight
Polybrominated diphenyl ethers (pbdes) 0.1% by weight

It should be noted that under specific exempted applications, where lead is used as an alloying element the following limits are applied in accordance with the regulations.

Copper and copper alloy parts use less than 4% by weight of each homogeneous component.

Steel and steel alloy parts use less than 4% by weight of each homogeneous component.

Aluminium and aluminium alloy parts use less than 4% by weight of each homogeneous component.

Only dispose of in authorised sites for electrical and electronic waste, do not dispose of with general refuse or landfill waste.

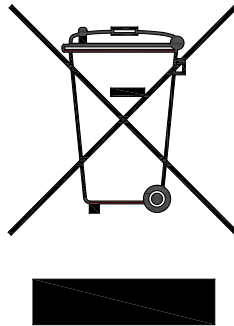

11.2 WEEE Statement

WEEE (Waste Electrical & Electronic Equipment) 2012/19/EU.

In relation to implementing the legislation, Parweld has established relevant recycling and recovery methods. We have been fully compliant against the marking requirements since August 2005. Parweld is registered in the UK with the Environment agency as detailed below. For WEEE compliance outside the UK please contact your Supplier/Importer.

Parweld is registered with a compliance scheme Official registration number is WEE/FD0255QV.

When your equipment reaches the end of its service life you should return it to Parweld where it will be reconditioned or processed for recycling.

11.3 Statement of Warranty

Limited Warranty:

Parweld Ltd, hereafter, "Parweld" warrants its customers that its products will be free of defects in workmanship or material. Should any failure to conform to this warranty appear within the time period applicable to the Parweld products as stated below, Parweld shall, upon notification thereof and substantiation that the product has been stored, installed, operated, and maintained in accordance with Parweld's specifications, instructions, recommendations and recognized standard industry practice, and not subject to misuse, repair, neglect, alteration, or accident, correct such defects by suitable repair or replacement, at Parweld's sole option, of any components or parts of the product determined by Parweld to be defective.

Parweld makes no other warranty, express or implied. This warranty is exclusive and in lieu of all others, including, but not limited to any warranty of merchantability or fitness for any particular purpose.

Limitation of Liability:

Parweld shall not under any circumstances be liable for special, indirect or consequential damages, such as, but not limited to, lost profits and business interruption. The remedies of the purchaser set forth herein are exclusive and the liability of Parweld with respect to any contract, or anything done in connection therewith such as the performance or breach thereof, or from the manufacture, sale, delivery, resale, or use of any goods covered by or furnished by Parweld whether arising out of contract, negligence, strict tort, or under any warranty, or otherwise, shall not, except as expressly provided herein, exceed the price of the goods upon which such liability is based. No employee, agent, or representative of Parweld is authorized to change this warranty in any way or grant any other warranty.

Purchaser's rights under this warranty are void if replacement parts or accessories are used which in Parweld's sole judgement may impair the safety or performance of any Parweld product.

Purchaser's rights under this warranty are void if the product is sold to purchaser by non-authorized persons.

The warranty is effective from the date that the authorized Distributor delivers the products to the purchaser. Notwithstanding the foregoing, in no event shall the warranty period extend more than the time stated plus one month from the date Parweld delivered the product to the authorized distributor.



Parweld Limited
Bewdley Business Park
Long Bank
Bewdley
Worcestershire
England
DY12 2TZ

Tel. +44 1299 266800
Fax. +44 1299 266900

www.parweld.com
info@parweld.co.uk