

**NOTE: 10T HEAVY DUTY HORIZONTAL PIPE ROLLER**

MAX CAPACITY: 20000LBS (9000KG)  
 MAX DIAMTER: 48"  
 FOOTPRINT: 1000IN^2 OR 20PSI @ MAX CAP.

**HARD URETHANE ROLLERS  
 c/w TIMKEN TAPER BEARINGS**

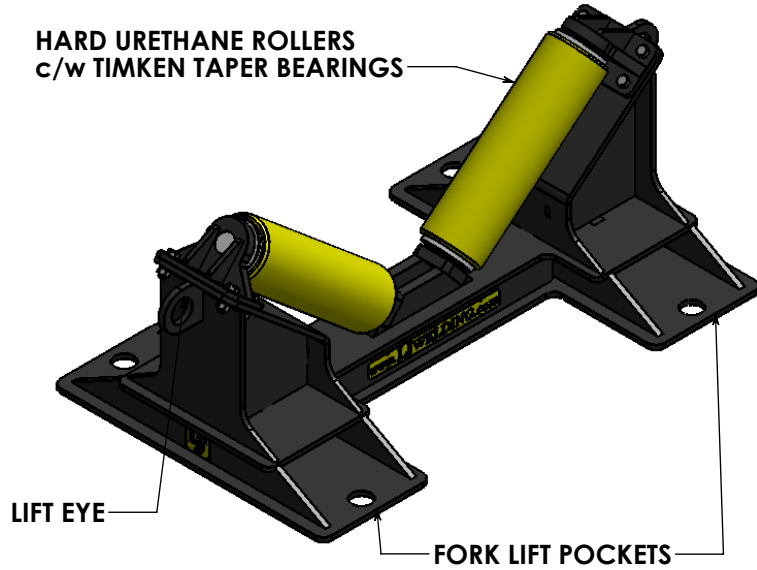

LIFT EYE

FORK LIFT POCKETS

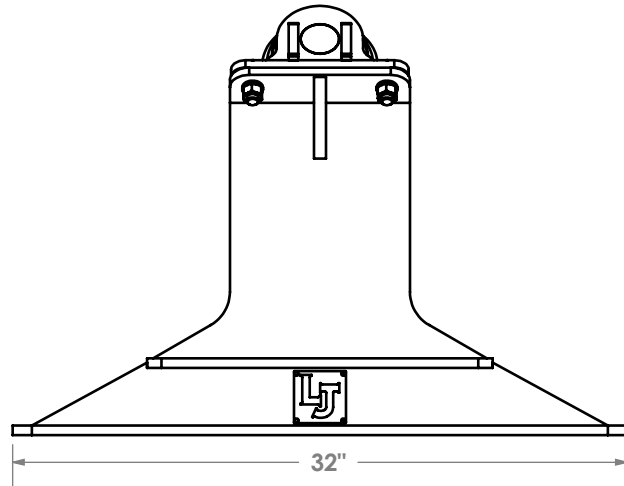

32"

Ø 48"

Ø 40"

1"

40°

100°

32 1/2"

Ø 2 1/2"

Ø 6"

3"

www.LJWELDING.com

9 1/2"

29 3/4"

52"

REV	REVISION DESCRIPTION	DATE	MADE BY
2	100 angle	Mar 16/09	TWR
1	120 angle	Mar 16/09	TWR

THE INFORMATION CONTAINED IN THIS DRAWING IS THE SOLE PROPERTY OF LJ WELDING & MACHINE ANY REPRODUCTION IN PART OR WHOLE WITHOUT WRITTEN PERMISSION OF LJ WELDING & MACHINE IS STRICTLY PROHIBITED

**APEGGA PERMIT NUMBER: P9801**

UNLESS OTHERWISE SPECIFIED ALL DIMENSIONS ARE IN INCHES  
**DEFAULT TOLERANCES**  
 LINEAR DIMENSIONS:  
 X.X=±.030" X.XX=±.015" X.XXX=±.005"  
 FRACTIONAL: ±1/16"  
 SAW: +0, -3/32"  
 HOLES: +1/64", -0  
 ANGULAR: ±1/2°  
 CONCENTRICITY: ±.010" TIR  
 MACHINE FINISH: 125 RMS  
 MACHINE INTRNL RADII: .015"  
 BREAK ALL SHARP CORNERS

DRAWN	DATE
TWR	MAR 13/09
CHKD	DATE
APPR	DATE



MATERIAL SPECIFICATION	DESCRIPTION			
STOCK DESCRIPTION	48" X 20,000# HRZ PIPE RLLR			
GRADE	FILE	WEIGHT (LBS)	PART NUMBER	REV
RAW MATERIAL	HZM-100-2	660		0

SCALE: 1:10	DO NOT SCALE FROM DRAWING	SHEET 1 OF 1
-------------	---------------------------	--------------